

Part Replacement | Ellipticals

>> Pedal Axel

Tools Required:

- Metal Cylinder: 3 to 4 inch. long, 30mm diameter
- C-Clamp: 10 inch. Jaw Opening & 6 inch. throat depth
- Rubber Mallet | Hammer
- 14mm, 15mm, 17mm Socket and Combination Wrenches
- Phillips Screwdriver
- Crank Puller
- 4mm, 5mm Allen Wrench

Procedure:

1 | Turn the unit off. Unplug the unit from the wall.

Remove the Side Covers:

Frame Style

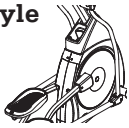

2 | Using the 5mm Allen wrench, remove the lower link arm bolt (A) from the lower handlebars. (F1)

3 | Using the 5mm Allen wrench, remove the pedal arm bolt (B) from the pivot tube. (F2)

4 | Remove the crank disk cap from the crank disk cover. (F1)

5 | Using the 14mm socket, remove the crank nuts, set aside for use in attaching the new pedal axel.

6 | Using the crank puller, remove the crank disks from the side covers.

7 | Move on to Step 8. Page 2.

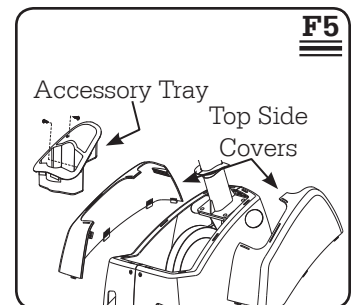
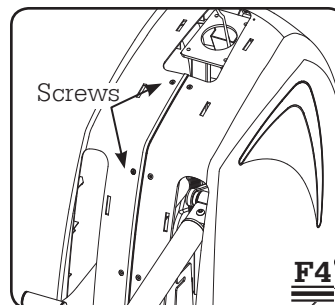
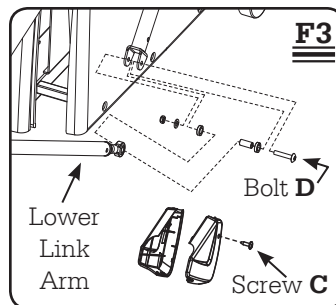
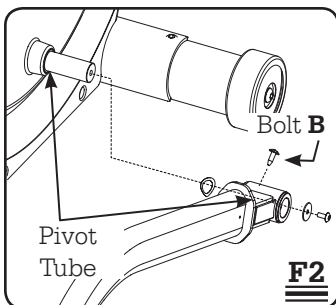
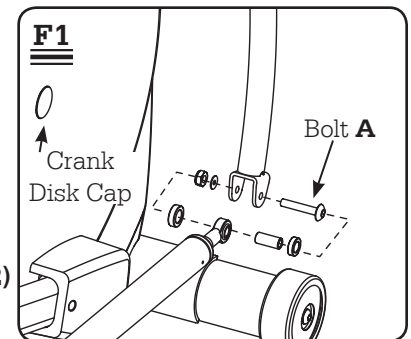

Remove the Side Covers:

Frame Style

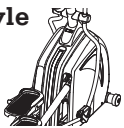

2 | Using the screwdriver, remove screw (C) to detach the outside elbow covers. (F3)

3 | Disconnect bolt (D) and attachments (F3) in order to disconnect the lower link arm from the lower handle bar.

4 | Remove the top cover to expose 8 of the screws attaching the side covers to the frame. (F4) (If the unit has accessory trays and top side covers, remove them. (F5))

5 | Using a screwdriver, remove screws attaching the side covers to the frame.

6 | Remove the ac adapter receptacle from the side cover if applicable. (F6 & F7)

7 | Remove side covers to expose the pedal axel. Move on to Step 8. Page 2.

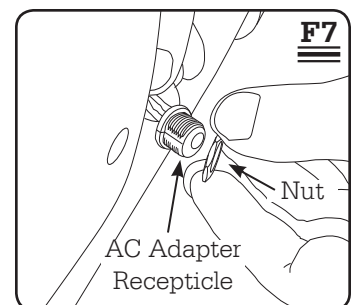
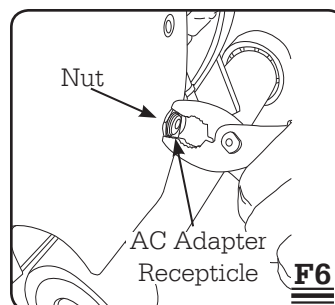

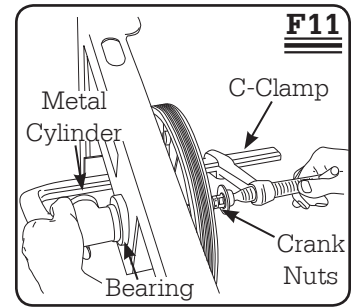
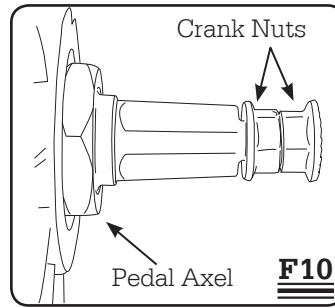
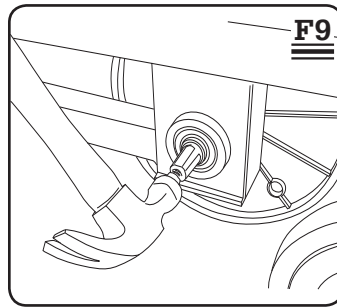
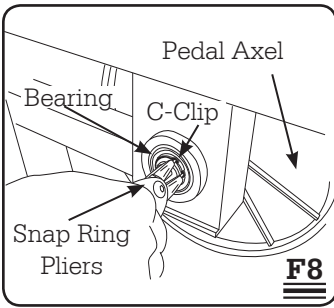

Removing the Pedal Axel and Remaining Bearing

- 8 | Using snap ring pliers, remove the c-clip. **(F8)**
- 9 | Using the hammer, knock out the old pedal axel. **(F9)**
- 10 | Place the screwdriver against the remaining bearing from the opposite side (On figure **F11**, the right side), using the hammer, gently knock the bearing from the frame.

Attaching the New Bearing

- 11 | Place new bearing in the same position as old bearing.
- 12 | Position the metal cylinder on top of the new bearing.
- 13 | Using the hammer, gently tap bearing in place. Do not tap directly on bearing.

Attaching Pedal Axel

- 14 | Place the two extra crank nuts on the pedal axel facing in the opposite direction. **(F10)** These are used to protect the threads on the pedal axel.
- 15 | Using the hammer, tap gently on the crank nuts to line up the pedal axel to the frame.
- 16 | Place the metal cylinder over the newly attached bearing. **(F11)**
- 17 | Using the c-clamp, tighten the pedal axel into place. It should make a popping sound when it is firmly in place. **(F11)**

Note: To reassemble the unit, follow the above instructions for removing the side covers in reverse.